

Block Diagram Representation of Controller Components of Distributed Power Flow Controller

Dr. M.S. Priyadarshini a*

^a Associate Professor, Department of Electrical and Electronics Engineering,
K.S.R.M College of Engineering (Autonomous), Kadapa

Corresponding author.

Correspondence: Dr. M.S. Priyadarshini
E-mail: priyadarshini@ksrmce.ac.in

Article info

Received 13th May 2022 Received in
revised form 30 July 2022 Accepted
30 September 2022

Keywords

Central controller, Distributed Power
Flow Controller, Series converter
control and Shunt converter control

[https://sajet.in/index.php/
journal/article/view/249](https://sajet.in/index.php/journal/article/view/249)

Abstract

In this paper, an attempt is made to present the controllers used for a power flow controller, termed as Distributed Power Flow Controller (DPFC). This comes under the category of Flexible AC Transmission Systems (FACTS) devices. DPFC emerges from the unified power flow-controller (UPFC), a most powerful FACTS device which can be used for both shunt and series control. So DPFC inherits the same control capability of simultaneous adjustment of line impedance, transmission angle and the bus voltage magnitude, which are the dynamic control parameters. The DPFC control and the functions of the different components for shunt and series controllers of DPFC are presented. These components can be obtained from Simulink Library of MATLAB environment and simulation model is obtained in this paper to check the dynamic response of DPFC.

1. Introduction

To necessitate the growing demand of electric power it is desirable to control the power flow in a power-transmission system in a fast and reliable manner. Power flow is controlled by devices that attempts to vary the dynamic parameters of a system, such as voltage magnitude, line impedance and transmission angle. Any variation in voltage, current, or frequency which may lead to an equipment failure or malfunction is potentially a Power Quality problem [1]. The flexible ac-transmission system (FACTS), utilized for power-flow control, is defined by IEEE as “a power-electronic based system and other static equipment that provide control of one or more ac-transmission parameters to enhance controllability and increase power-transfer

capability” [2]. Any new power flow control device must have both acceptable cost to electric utilities and reliability for power system. The unified power flow controller was proposed for real-time control and dynamic compensation of ac transmission systems, providing the necessary functional flexibility required to solve many of the problems facing the utility industry [3]. Currently, the unified power-flow controller (UPFC), is the most powerful FACTS device, which can simultaneously control all the parameters of the system: the line impedance, the transmission angle, and bus voltage [3]. In a unified power flow controller, a combination of separate shunt and series converters are controlled in a coordinated manner. In the combination, current is injected into the system with the shunt controller and voltage in series in the line with the series controller. By combining these two approaches, the new FACTS device-distributed power flow controller (DPFC) is achieved [4]. The distributed power flow controller emerges from UPFC with eliminated common dc-link interconnection to enable the independent operation of the series and shunt controllers. Series-shunt devices such as UPFC can be used for accomplishing both functions with maximum flexibility and higher cost [5]. DPFC can simultaneously adjust the voltage magnitude, line impedance and the transmission angle, thereby independently controlling the active and reactive power flow through lines.

2. DPFC Configuration

The DPFC consists of several series-connected converters to inject a voltage, with controllable magnitude and phase angle in series with the transmission line and one shunt converter to supply or absorb the active power demanded by the series converter. Possibly the most significant issue in terms of grid utilization is that of active power flow control [6]. The shunt and series converters within the DPFC are independent and has their own individual dc capacitors to provide the required dc voltage represented by DPFC configuration in Figure 1.

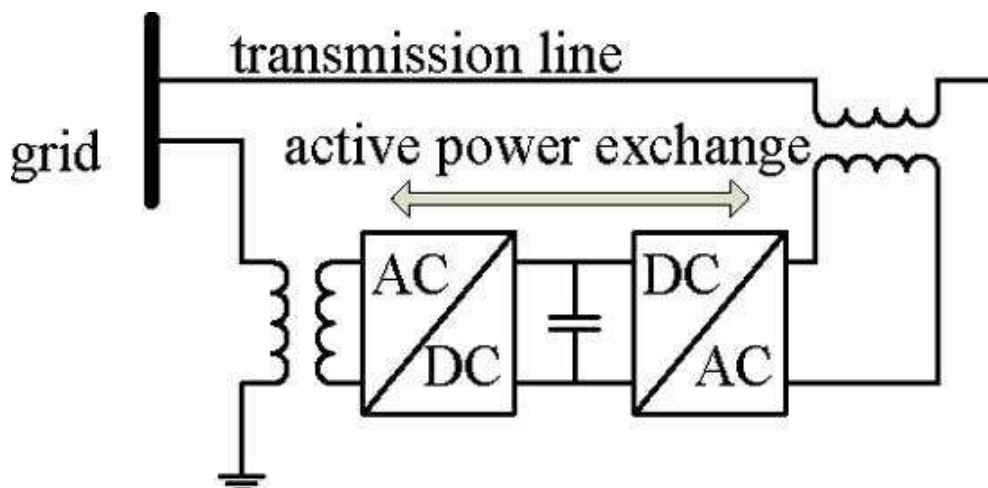

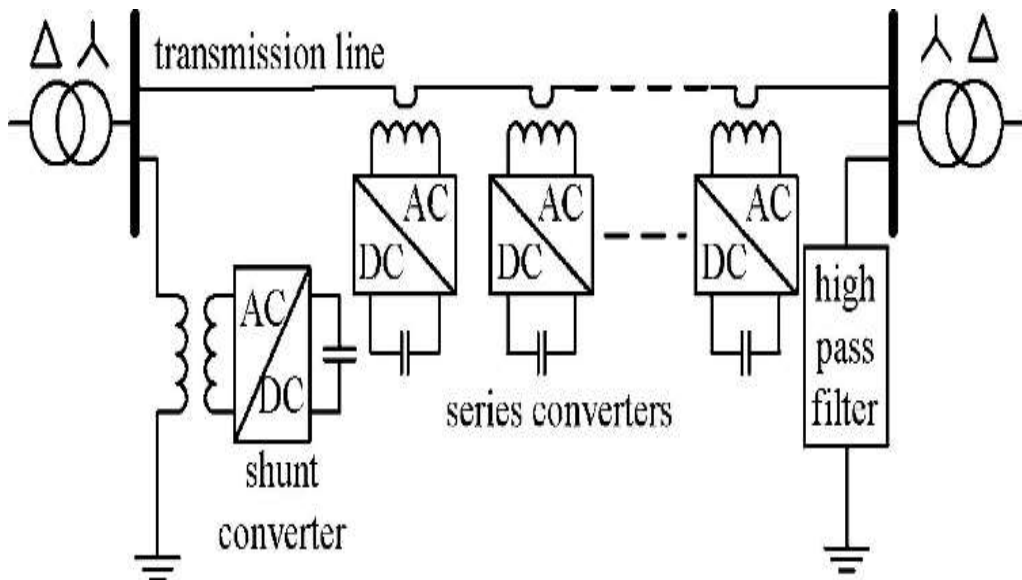

Figure 1. DPFC Configuration

The shunt converter is similar as a static compensator STATCOM, while the series converter employs the D-FACTS concept, which is to use multiple single-phase converters instead of one large rated converter [4]. The D-FACTS is a distributed solution to power flow control of series converters. D-FACTS sustain the operation of the system even during contingency conditions, improving the reliability of the overall network [6]. Each converter generates the voltage at two different frequencies at the same time, one at the fundamental frequency and the other at the third-harmonic frequency. The link between the fundamental frequency and third-harmonic frequency circuits is the active power balance of each converter.

3. Block diagram representation of different Controller Components of DPFC

DPFC consists of three types of controllers termed as central control, series control and shunt control to provide control for multiple converters. The central control generates the voltage-reference signals for the series converters and reactive current signal for the shunt converter of the DPFC according to the system requirement. These generated reference signals are at the fundamental frequency. The terms $i_{sh,ref}$ and $V_{se,ref}$ are the reference signals given by the central control to the shunt control and series controllers respectively at the fundamental frequency. The series controller maintains the capacitor dc voltage of its own converter by using the third-harmonic frequency components and generates series voltage at the fundamental frequency that is referenced by the central control. Shunt control injects a constant third harmonic current into the line to provide active power for the series converters. The shunt and series controllers maintain their individual converter parameters. To analyze the operation of DPFC, Simulink models can be built in MATLAB environment according to the simplified

representations for DPFC control, shunt and series converter control block diagrams are shown in Figures 2 and 3.

The entire DPFC model along with shunt and series control is placed between two buses supplied from two grids. The control of power flow through the transmission lines by DPFC is obtained by varying the voltage injected by the series converter at the fundamental frequency. The dc voltage of the series converter is stabilized before and after the step change. The measured series converter voltage and current through the line, from which if the series converter can inject or absorb active and reactive power. The series converters are able to absorb and inject both active and reactive power to the grid at the fundamental frequency. A low pass digital filter is used to filter the harmonic distortions contained in voltage and current at the fundamental frequency. A delay is caused in the measured active and reactive power. Park's transformation is used for abc to dq0 conversion. Figures 2 and 3 depict the interconnection between the various components used in series and shunt controllers of DPFC.

4. Conclusion

The principle of DPFC can be verified by simulation of step response of DPFC. The power transmission through the line is at the third-harmonic frequency. The shunt and series converters exchange active power at the third-harmonic frequency. The block diagrams of the various components used in DPFC shunt and series controllers are represented. Each series converter with its own series control, absorbs and injects controllable active and reactive power to the grid at the fundamental frequency. The shunt converter control injects a constant third-harmonic current into the line to provide active power for the series converters. DPFC has high control capability and separated installation of the shunt and series controllers provides an improved reliability.

References

- [1] R.C.Dugan, M.F.McGranaghan and H.W.Beaty, *Electrical power systems quality*, New York: McGraw Hill, 1996.
- [2] N.G.Hinorani and L.Gyugyi, *Understanding FACTS: Concepts and Technology of Flexible AC Transmission Systems*. New York: IEEE Press, 2000.
- [3] L.Gyugyi, C.D. Schauder, S. L. Williams, T. R. Rietman, D. R. Torgerson and A. Edris, "The unified power flow controller: A new approach to power transmission control," *IEEE Trans. Power Del.*, vol. 10, no. 2, pp. 1085–1097, Apr. 1995.
- [4] Z.H.Yuan, S.W.H de Haan, J.B. Ferreira and D.Cvoric, "A FACTS Device: Distributed Power-Flow Controller (DPFC)", *IEEE Transactions on Power Electronics*, vol.25, no.10, October, 2010.
- [5] M. D. Deepak, E. B. William, S. S. Robert, K. Bill, W. G. Randal, T. B. Dale, R. I. Michael, and S. G. Ian, "A distributed static series compensator system for realizing active power flow control on existing power lines," *IEEE Trans. Power Del.*, vol. 22, no. 1, pp. 642–649, Jan.2007.
- [6] D. Divan and H. Johal, "Distributed facts—A new concept for realizing grid power flow control," in *Proc. IEEE 36th Power Electron. Spec. Conf.(PESC)*, 2005, pp. 8–14.
- [7] L. Huber, B. T. Irving, and M. M. Jovanovic, "Review and stability analysis of PLL-based interleaving control of dcm/ccm boundary boost pfc converters," *IEEE Trans. Power Electron.*, vol. 24, no. 8, pp. 1992–1999, Aug. 2009.

- [8] Y. Zhihui, S.W. H. de Haan, and B. Ferreira, "Utilizing distributed power flow controller (DPFC) for power oscillation damping," in Proc. IEEE Power Energy Soc. Gen. Meet. (PES), 2009, pp. 1–
- [9] Y. Zhihui, S. W. H. de Haan, and B. Ferreira, "Dpfc control during shunt converter failure," in Proc. IEEE Energy Convers. Congr. Expo. (ECCE), 2009, pp. 2727–2732.
- [9] M. Mohaddes, A. M. Gole, and S. Elez, "Steady state frequency response of statcom," IEEE Trans. Power Del., vol. 16, no. 1, pp. 18–23, Jan. 2001.
- [10] L. Gyugyi, C. D. Schauder, and K. K. Sen, "Static synchronous series compensator: A solid-state approach to the series compensation of transmission lines," IEEE Trans. Power Del., vol. 12, no. 1, pp. 406–417, Jan. 1997.
- [11] Sivakumar, S.A., Naveen, R., Ibrahim, S.J.A. et al. Two-ways chip to chip communications through 2-dimensional photonic structures via photonic integrated circuit. Opt Quant Electron 55, 661 (2023). <https://doi.org/10.1007/s11082-023-04941-3>
- [12] Verma, P., Jyoti, K., Sahni, V. et al. Synthesized feature learning model on news aggregator for chatbot. Soft Comput (2023). <https://doi.org/10.1007/s00500-023-08069-0>.
- [13] Chinnappan, C.V.; John William, A.D.; Nidamanuri, S.K.C.; Jayalakshmi, S.; Bogani, R.; Thanapal, P.; Syed, S.; Venkateswarlu, B.; Syed Masood, J.A.I. IoT-Enabled Chlorine Level Assessment and Prediction in Water Monitoring System Using Machine Learning. Electronics 2023, 12, 1458. <https://doi.org/10.3390/electronics12061458>
- [14] N. Krishnaraj, R. Vidhya, R. Shankar and N. Shruthi, "Comparative Study on Various Low Code Business Process Management Platforms," 2022 International Conference on Inventive Computation Technologies (ICICT), Nepal, 2022, pp. 591-596, doi: 10.1109/ICICT54344.2022.9850581.
- [15] J. Ramprasath, N. Krishnaraj & V. Seethalakshmi (2022) Mitigation Services on SDN for Distributed Denial of Service and Denial of Service Attacks Using Machine Learning Techniques, IETE Journal of Research, DOI: 10.1080/03772063.2022.2142163
- [16] Natarajan Krishnaraj, Chirag Madaan, Sanjana Awasthi , Raggav Subramani , Harsh Avinashand Sankalp Mukim Common vulnerabilities in real world web applications, doors-2023: 3rd Edge Computing Workshop, April 7, 2023, Zhytomyr, Ukraine